

VRLA / SLA Battery series is designed with AGM Long life / Duration In High Performance Plate with Gain Extra Powder in Purify Electrolyte. Innovation Design of Fully Maintenance Free in Float Life 12 years. This is Highly Suited to Backup Applications in UPS/EPS, Security Alarm System, Deep Cycle Applications use in Telecom System and Solar System.



Feature

- Smart UPS Battery Design up to 15%
- Battery Capacity 75Ah/1250W - 15min
- AGM/SLA - Seal Lead Acid Battery
- Maintenance Free Battery Operation
- Non-Spillable Construction Design
- ABS container & Cover UL94HB-0
- Safety Value in Explosion proof
- CE & UL Product Certification
- ISO9001 & ISO14001 Certified Factory

Application

- UPS & EPS
- Emergency System
- Communication Eq.
- Control Equipment
- Solar System
- Alarm System
- Medical Equipment
- Cable TV & CCTV
- Solar System

Specifications

Voltage Normal	: 12 VDC	in 6 Cell
Capacity @20Hr	: 79Ah @3.97A/	48W
@ 5Hr	: 63Ah @12.6A/	160W
@ 1Hr	: 46Ah @46.3A/	546W
@15min	: 29Ah @116 A/	1278W (*UPS)
@ 5min	: 17Ah @200 A/	2142W (*UPS)
Max. Discharge	: 1000A @14C	
Max. Charge Current	: 22A @0.3C	
Internal Resistance	: Apporx. 6 mΩ	Full Charge at 25°C
Design Float Life	: 12 years	at 25 °C
Cycle Lift Service	: 1500 cycles	at DOD 25%
Float Charge Voltage	: 13.5-13.8V	(-20mV/°C) at 25°C
Cycle Charge Voltage	: 14.4-15.0V	(-30mV/°C) at 25°C
Operation Temp.	: Normal 25+ / -3 °C	
	: Discharge -15 - 50 °C	
	: Charge -15 - 50 °C	
	: Storage -15 - 50 °C	
Self Discharge	: more than 6 Month	at 25°C
Terminal	: M6	
Container Material	: ABS UL94 HB-0	(Option :UL94V-0)
Physical	: 260x168x211mm - 22.5 Kgs	

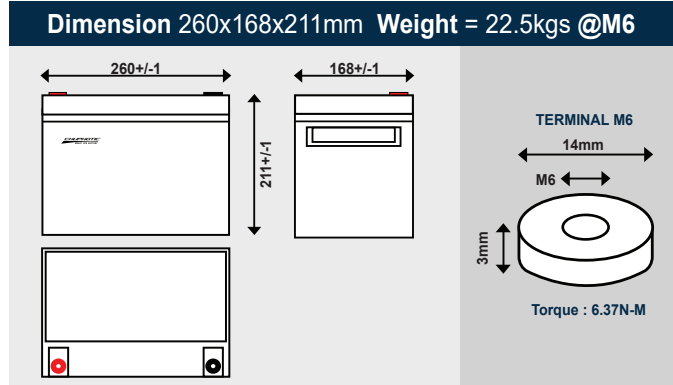

Terminal Voltage (V) and Discharge Time

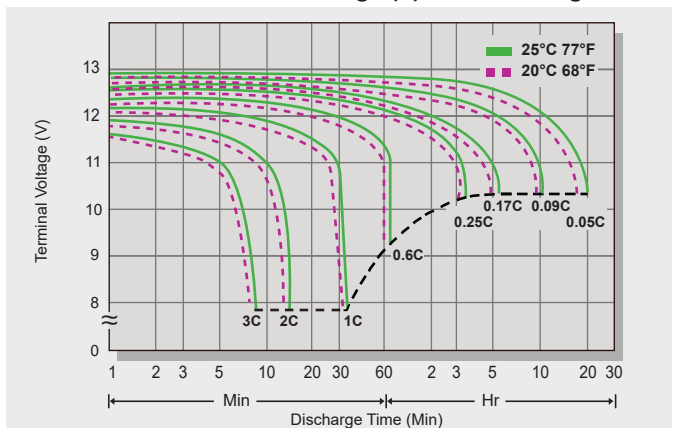

Battery Voltage and Charge Time for Standby Use

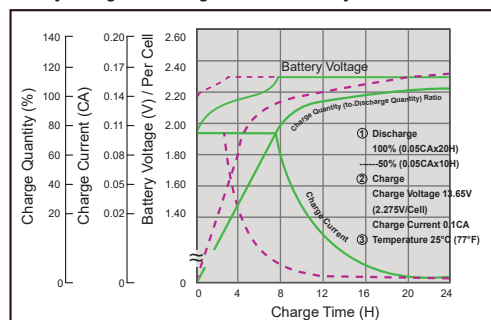

Battery Voltage and Charge Time for Cycle Use

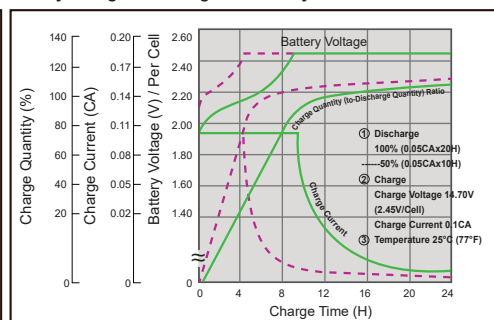

Cycle Service Life

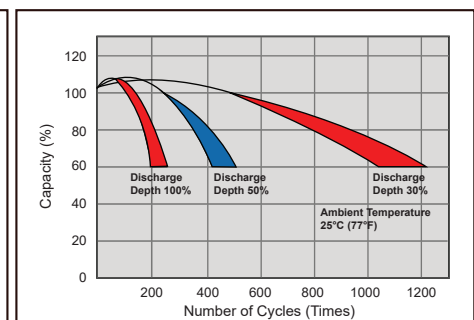

Constant Current(Amp) and Power (Watt/Box) Discharge Table

CHU.BRO-05.BAT.UB1275-1250W.Rev1.00/2020

VRLA-Battery Performance : %DOD, Constant Current, Constant Power (25°C / 10.2 F.V.)

Discharge Time	5 Min	10Min	15Min	20Min	30Min	60Min	2Hr	3Hr	5Hr	10Hr	20Hr
%DOD	22%	32%	39%	42%	49%	62%	70%	81%	84%	100%	106%
Cons. Current	200A	146A	116A	94.5A	73.5A	46.3A	26.2A	20.3A	12.6A	7.51A	3.97A
Cons. Power	2142W	1614W	1278W	1039W	828W	546W	301W	232W	160W	90W	48W